

# Propane Oven Lighting Instructions

## TO LIGHT THE CHINA HAT PILOTS: (Open top burners)

1. The main gas valve should be “OFF” for at least five minutes to allow any accumulated gas to escape the combustion chamber.
2. Remove spider rings, open top grates, and locate the pilots.
3. Turn supply gas “ON” and hold match close to the pilot head. The pilot should light.
4. Turn the manual gas control to the “ON” position. The main burners should light.

## TO TURN THE CHINA HAT PILOTS OFF:

1. Turn the supply gas control to the “OFF” position and ensure all burners are off.

NOTE: Pilots cannot be shut off unless the main gas supply to the appliance is shut off.

## TO LIGHT THE OVEN PILOT:

Remove the lower kick panel below the oven door. Open oven door and remove the oven rack. Remove bottom. 1. The safety valve should be closed for at least five minutes to allow any accumulated gas to escape the combustion chamber.

2. Turn the thermostat to the lowest possible setting.
3. Depress and hold down the red button while lighting the pilot. Hold the button down for about 45 seconds.
4. Release the reset button. The pilot should stay lit.
5. Set the thermostat to the desired temperature. The main burners should light.

## TO TURN OFF THE OVEN PILOT: (See Fig. 3)

1. Turn the thermostat to the lowest possible setting.
2. Blow out pilot. The safety valve will automatically shut off the gas supply system.

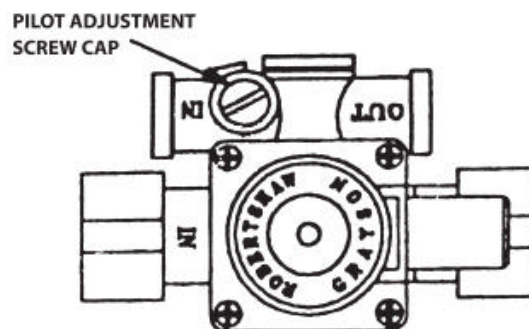

Figure 3